

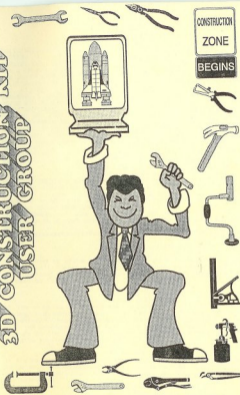

- Hints & Tips
- Usefull Routines
- Letters Page
- Beginner's Section



3D CONSTRUCTION KIT USER GROUP



Magazine Issue 11
Feb/Mar 1993

EDITORIAL

Welcome to issue 11 of the 3D Construction Kit User Group Newsletter.

I've been quite busy again, since the last newsletter went out, not as busy as between the previous issue though - thank goodness. I've managed to sent out English disks to everyone now and also arranged for Domark to replace all the videos that went out with the Atari ST version that happened to be in German. You should all have received them by now, if not, or if I have missed anyone, then please let me know. Work is progressing nicely on the very latest version which, hopefully, will eliminate all the little niggles that everyone has been telling me about on previous versions and I'll arrange to swap all your disks as soon as I get a stock in. I can't wait for you all to get versions that you are all completely happy with. Kit 2 is a fantastic program!

There have been a lot of new members joining us, with Kit 2 recently, so for the new members, please note that the 16/32 bit routines contained in the newsletters apply to ALL 16/32 bit machines - it doesn't matter if the contributor uses a different computer - the language is the same. Also some of the 8 bit routines can be adapted for your machines also. I did print a little translation of the differences between the 8 and 16 bit commands in a previous newsletter so if you don't have that and would like the list then please let me know and please don't forget to enclose a S.A.E.

For new members with Kit 1 and for 8 bitters who have upgraded to 16 bit and would like to upgrade to Kit 2, upgrades can be obtained from me at a cost of £20 (together with your old program disks) at the usual address. On this occasion only please make cheques payable to Domark Ltd. I know it is a pain but please don't include payments to me in those cheques but make separate ones payable to Mandy Rodrigues please or there will be a considerable delay in receiving everything you asked for. Oh! I nearly forgot AGAIN, Kit 2 will only work with a minimum of 1 meg. PC versions are compatible with EGA/VGA machines (NOT CGA), please state 5.25 inch or 3.5 inch disk as dual packs are no longer available.

We have another great jazzy cover this issue, provided by Dominique Watson. I like the piccy of me on the back cover! If anyone would like to try their hand at designing a cover for the Newsletter please feel free! Also I am getting a bit short on routines for 8 and 16 bits but especially 8 bit so if you have anything you think might help other members, why not send them in for the next newsletter. Also it would be nice to have more routines for Kit 2 in the next newsletter - I know you are all still learning how to use it and all the new commands but I'm sure you will do your best!

I hope you all enjoy this issue and find lots to interest you. There are quite a few useful tips for Kit 2 owners as well as some great routines for all versions, so I'll leave you all in peace to get on with the rest of the newsletter. I'll see you all again in the next issue which will be the April/May 1993 issue. Deadline for that is 1st April. You will all notice that this issue has come out a lot earlier than previous issues? Just shows what happens when I don't promise an early distribution date! I fooled Murphy this time! Oooops! I hope that doesn't mean we are going to have a postal strike - I'd better keep my mouth shut!

Mandy

LETTERS

Dear Mandy

I'm in a quandary: I'm up the creek and in a jam, 3DCK, second version, needs one megabyte of RAM! My Atari's a 520 - so, could you advise me, Ma'am?

I could wait until the "Falcon" comes on stream, eventually, Or, I could just drop Atari and invest in a P.C. The trouble with the latter would be DOS - it seems to me.

I'm getting on now (I'm a gran'dad) so I have no time to waste, Learning DOS commands for everything from "close" to "cut and paste". P'rhaps I am a WIMP, but I think GEM is better "interfaced".

Does the C-Kit run in "Windows"? That's an option, I suppose. 'Though I'll need a lot of RAM and hard disk space, if I use those. If you can't say perhaps "Inventive's" Mr Andrews knows!

Have they modified the programme for the "Falcon" system yet? And, have Domark dropped Atari? That's the latest news I get? If they have, I may be forced to - though I'd do so with regret.

If I do change my computer can I get a cheap upgrade On the software that I've ordered, or must full price still be paid? A speedy answer would be helpful, as decisions must be made.

I could, of course, give up computing and go to the Rhondda. Tales Tell me houses are quite cheap there - and I'm very fond of Wales. 'Twould be healthier for me, no doubt, walking in the hills and dales.

Pete Spooner, Abingdon, Oxon - ATARI ST

Dear Pete, I'm awfully sorry and for your forgiveness I beg, That I didn't state earlier that you need to have 1 Meg. If you decide to change your computer to a PC with all that DOS I'll swap your upgrade package with the greatest pleasure because The fault was mine - I quite agree - I've had to add a half meg too So Atari Kit 2 I can see. It's cost me £40 but that I do not rue! I too heard Domark won't be supporting Atari but not heard direct I wondered if it was a rumour but I'm assured 'tis a fact I suspect. If I can use DOS then anyone can! 'Cause I'm not too bright I suppose But sad fact is that problems occur if you load Kit through windows! If you do decide to up your roots and head for the hills and dales We'll do some computing together - there's always a welcome in Wales!

.....Mandy

Dear Mandy

I have noticed through the letters pages that some people have difficulty in making certain objects. They can make a simple house, with a few blocks but other objects are a bit more difficult. Anyhow, the point is that if anyone with an Atari wishes to have/need something drawing for them, I will be only too glad to have a go for them for free, providing they send a SAE and blank disk and let me know what object it is they need. They should state the area size they need and how large in the area the object has to be, e.g. quarter the size of the area or some height co-ordinates etc. If they enclose a rough drawing it would help but isn't essential. Also state how complicated or detailed they want the object to be as more objects slow processing time down in an area. I just thought it was a nice

way to help some people out who may have drawn an area, for example, but are finding it a bit difficult to get the main object (dinosaur, dalek, dog or whatever) drawn. For anyone else with another computer I can also draw an exploded step-by-step drawing on paper if they give details etc. Don't get me wrong though, I'm no Van Gogh but I have been to art collage and I can handle most drawings etc.

Tony Hartley - ATARI ST
19 Kipling Close, Lockwood, Huddersfield, HD4 5HA

What a kind offer, Tony, I'm sure it will be appreciated. I don't know about Van Gogh but after seeing your PD disk with Fast-Town I don't think you should under estimate your talent!.....Mandy

Dear Mandy

I am involved in a project which realises an educational game. In general the player moves within a kind of temple. By selecting objects with the help of the mouse cursor the user gets information about the object or other support. So far as I know your Kit, which I bought in '91 is ideal but I am missing some features. Surfaces can't have a structure e.g. there are patterns on the walls of our temple and a fence surrounds the site. This has poles and so on but is not a wall. We have a painting on the wall and some rooms are separated by curtains. It seems that it is only possible to use the Kit with the original disk in the drive which may damage the disk eventually. Please can you help?

Hans-Juergen Thiess, Berlin - PC

It looks as if you are asking for Texture Mapping - i.e. mapping of a 2 dimensional image onto the 3 dimensional facets of an object. This cannot be supported in the 3D Kit for reasons of speed, the calculations required to map an image onto a 3D plane are quite considerable and the machines Incentive support are not capable of it. An argument against this conclusion is, of course, the current spade of games using what appears to be texture mapping, however, as these are games products, certain assumptions may be made about the way the program works and these assumptions cause restrictions which will not be noticed in a controlled game situation. The 3D Kit on the other hand, is a general product capable of producing a wide variety of effects and as such no assumptions may be made. This means that a true texture map algorithm must be implemented if at all, and as previously explained would be far too slow. From your other enquiry about having to use the disk in the drive, this, I presume, is because you have a very early version that Domark inadvertently put copy protection on in the initial release. If you return your disks for an upgrade this will solve the problem.....Paul from Incentive and Mandy

Dear Mandy

Three weeks ago I purchased 3D Kit 2 - German version. But I have a problem in that the pull-down menu point BEDINGUNGEN doesn't work. All the other menus work apart from this - please can you help?

Marcus Schaffner, Germany - KIT 2

This was a bug in version 2.03 of Kit 2 which is fixed for version 2.05 and will be ready for exchange shortly.....Mandy

Dear Mandy

I have a number of queries regarding Kit 2 (v.2.01) that you sent me just before Christmas. When you set MOV attribute of an object and then more it, its position is reset. If you do not set the MOV attribute you can move an object using MOVE in an animator (contrary

to the manual) but then the new position of the object becomes its new set position. Why do we have a Border - Locate when all other load data menus allow us to move through the directories? What does the General Buffer Size do? Does the program only support LBM files?

Rafael Pelayo, Lewisham, London. KIT2

The reason why setting the MOV attribute and moving an object means that its position is reset is that when the MOV attribute is set the current position is stored as the default. This can be overcome by using the DEFAULTS button in the attributes editor which allows you to alter the default position. It also allows you to set the default position to the current position. Moving the object via an animator. This is because setting the MOV attribute gives the object a DEFAULT position chunk. If the MOV attributes is not set the object has no default position and therefore cannot be reset to its initial position when the world is reset. The reason we have a Border-Locate which is not like the normal load in Kit1 is because the borders are not actually loaded, when you "LOAD" a border you simply point to the border so that when a BORDER() command is issued the program knows where to look for it. As the border information chunks within the datafile must be a set length we cannot allow for pathnames as well as filenames in the border information chunk, as this would require about 256 bytes of name space to allow for deeply nested files, this in turn would increase the size of the datafile out of all proportion. Therefore the borders are restricted to being in a single directory which you must specify to begin with. In the PC version the General>Buffer Size doesn't do anything. The PC has no option to set the buffer size, However, on other versions there are and this menu option was mistakenly left in on the PC version, it has been removed for version 2.03 and onwards. The PC version doesn't only support LBM files but also supports PCX as long as the format is correct, i.e. 320 x 200 pixels in 256 colours. LBM files are IFF format files as saved from Deluxe Paint.....Paul from Incentive and Mandy

Dear Mandy

I would like some info. on Cosine and Sine. Also a list, if possible, of graphic files that are 3DK2 compatible. 3DKit 2 is fantastic and I can forgive the manual for not being totally comprehensive as the imagination is unbounded. Rotation of objects in smaller increments that 180 degrees during gameplay is very hard for me to achieve, I would love some help on this matter.

Ben, Chorlton, Manchester - PC KIT2

The sine and cosine functions in FCL return the sine and cosine values of the passed angle multiplied by 16384. This is because all maths in FCL is integer, i.e. no decimal places. As such, true sine and cosine values which range from -1 to 1 would be of no use whatsoever. Objects can be rotated in increments of 90 degrees, however smaller increments than this are not available because the FREESCAPE system requires that all objects are orthogonal, that is parallel to the world axes.....Paul from Incentive and Mandy

Dear Mandy

I am trying to create a TARDIS effect for my brother. I have a large cube (object 2) with a small cube sitting on top of it (object 3). I want the small cube to FADEBOUNCE for about five seconds and after that both cubes to fade out. I have the following code for object 2:

```
IF SHOT?  
THEN FADEBOUNCE (3)  
*
```



```
FADEOUT (2)
FADEOUT (3)
```

If I put a DELAY (100) at *, the program pauses when I shoot the large cube but before object 3 starts to fadebounce. In this case, when I shoot, there is a pause, then both cubes fadeout. I have also tried the following code:

```
IF SHOT?
THEN FOR (V50,1,5)
FADEOUT (3)
FADEIN (3)
NEXT
FADEOUT (2)
FADEOUT (3)
```

In this case, nothing happens at all when I shoot, even if I define VAR (50) before the FOR - NEXT loop. Please could you help me? Aside from these problems I have found the program to be exceptional and the whole family has enjoyed creating scenes.

Oliver Me11, Camberley, Surrey - kit 2

To obtain the effect required, i.e. FADEBOUNCE an object for five seconds and then fade out altogether requires that redraws are made, the code supplied has no allowance for redraws, this code should achieve the desired effect:

```
IF SHOT? THEN
FADEBOUNCE (3)
FOR (V30,0,100) Rem: 100 is delay value
WAIT
NEXT
FADEOUT (2)
FADEOUT (3)
ENDIF
```

Hope this gives the desired effect. Glad to know that you are so pleased with Kit 2, it is a fabulous program.....Mandy

Dear Mandy

I have loaded 3DK2 ver 2.01 and have run 3DSETUP. When I run 3DEDIT I get the following message "System error! 2". I have also had the message "Fatal error resources file". My system is Amstrad PC2386 DX20 65 MBHD, 4MB extended memory through' windows, MS DOS ver 4.1. Could you advise me how I can get the system running?

Michael Schonewald, Kirriemuir, Angus - PC KIT 2

The problem lies on the amount of system free memory. This value can be obtained by typing CHKDSK at the DOS prompt, there will be a number of values displayed, one of which is the free system memory, or maximum program size, to run the 3DKit this value must be greater than 540K. If it is not the AUTOEXEC.BAT and CONFIG.SYS files must be altered to remove anything that uses memory and is unnecessary for the execution of the Kit. Note that many problems such as this where the 3DEDIT program will not load properly or does not run at all have the same solution. This is because PC's only have 640K of base memory, the 3D Kit must run within this 640K and, because of the complexity of the product, it requires a great deal of this base memory for its own use. If there are other programs (such as DOS Shell, PC Shell etc.) started from within the AUTOEXEC.BAT or CONFIG.SYS files that use large portions of this base memory the Kit will not run.....Mandy

Dear Mandy

We are looking for a freelance programmer/company to help us develop a simple interactive game. In depth knowledge of 3D Construction Kit 2,

PC version and good creative skill is essential. The project is due to start in January or February 1993 and should last for approximately 1 month. Also any knowledge of interfacing other input devices such as joystick would be helpful. Please contact:

Peter Tysoe, Photosound Communications Ltd., Media House, Shire Hill, Saffron Waldon, Essex CB11 3BD Tel:0799 526767.

Dear Mandy

First of all I'd like to thank you for all your efforts in getting the upgrade to Kit 2 to me. I know that it's been hell for you the last few months, let's hope that Domark learn from all this! Well, now that I've got the Kit I'm now going to start to moan about it, ungrateful aren't I? The Manual: In the main it is quite good, although a bit patronising in the tutorial section, but very readable. However there is a glaring error in the FCL tutorial about arrays, one that is obvious to us "professionals" but may confuse the beginner no end, the manual says...

```
DEFARRAY (A1,10) Give array A1 10 elements
SETVAR (4,A1[5]) Set 5th element of the array to 4
```

NB Array subscripts start at 0 rather than 1, so in our previous example the first element of the array A1 will be 0 and the last element will be 9.

Spotted it yet? yes, that's right "set 5th element" should be "set 4th element" 'cause the subscript starts at 0!!

By the way, I think you were wrong when we spoke on the phone, the members know you well enough by now not to think you're being unnecessarily picky if you point out problems with the manual, just because you wrote the first one for Kit 1 and not this one. Finally, I would like to add my name to the list of those who would like to see a 3D Kit Conference sometime, it would be a lot of fun to meet and greet everyone and put a face to the name of Mandy Rodrigues, no doubt you'd end up totally plastered after everyone's bought you a drink to thank you for all your help!

Richard Exton, Bury, Lancs, Kit1 and 2

I've had quite a few letters from people who have expressed a keen interest in the proposed convention, Richard, I'll see what develops, but as for my getting plastered - as I've said before I become completely legless after just one drink so you'd better decide to buy me a coke instead.....Mandy

Dear Mandy

Hello to you and fellow Kit users, this being my first letter to the club. Although I do not get much opportunity to use the Kit at the present time, I nonetheless enjoy reading the Newsletters. First of all, in response to Reg McLoughlin's letter in the last issue: Predominately, the speed of the processor is what determines how fast a program runs, the faster the processor, the faster the program. More memory only helps to speed up a machine if having it avoids/reduces the need to repeatedly reload data from disk, with a good example of this being virtual memory. The only thing you and I can do is get a faster machine. I now own a 50mh 486 PC with 16mb of RAM. The difference between running something like Formula One Grand Prix on this machine and on my A2000 is quite something. By comparison my Amiga looks like a snail, not that I would sell it, you understand. Anyway, what I would like to know is having purchased the Amiga version of Kit 2 at the clubs reduced rate, can I also do the same for the PC?

Orn Jonasar, Aylesbury, Bucks - PC Kit 1 and 2

Many thanks for the useful information, Orn. Yes, you can upgrade again through me for the PC version of Kit 2 if you like.....Mandy

Dear Mandy

The last thing I would wish to do is to pry into your personal life but, as you treat us all as friends, when we write to you, I wondered if you would consider giving us a brief C.V., so that we can get a mental picture of the friendly soul that we are dealing with? This is only a suggestion and you may well think that it is better to keep your private and business life in separate compartments. That would be quite understandable and quite acceptable. Over to you!

Pete Spooner, Abingdon, Oxon - ATARI ST

I don't mind at all, Pete. I did tell everyone about myself in the first newsletter but a lot of people have joined since then and have wondered about me too. If it wouldn't bore you then here goes:

I am married with two children, a boy and a girl and, thank goodness, all the family are computer crazy (and we have enough of them to go round - though funnily enough everyone always seems to want to be on the computer that I happen to be on!). I used to be the editor of Adventure Probe magazine and ran my own software company but now I devote my time to running the User Group and what I have always loved to do, freelance writing. This is mainly for the monthly computer glossies where I write regular monthly columns under various (sometimes extremely stupid), pen names. I have had my own games published in the past but no longer do much programming - except on the Kit. Apart from these pastimes and looking after the home and family, I have various hobbies including oil painting (very rarely get time these days), singing (well, in Wales what do you expect?!), reading (favourites are Stephen King, Dean Koontz, Stephen Donaldson, David Gemmel and David Eddings), avid film watching (favourites are Ghost, Terminator II) and, perhaps most of all I enjoy playing computer adventure games. I run a telephone helpline for people who get stuck in adventure games as well as the Kit helpline.

I'm overweight (probably due to the time spent sitting in front of the computer instead of jogging), and will soon be middle aged but as they say that life begins at 40 I'm quite looking forward to it! Many of you have asked just how I got involved in this business in the first place. Well, quite a few years back, when Incentive released the Graphic Adventure Creator, I was asked to review, for a magazine, the game that won first prize in the GAC/Home computer club competition. There were some faults within the programming of the game and I rang Ian Andrew to mention this to him. He asked me if I could fix it and then I did another couple of jobs for him and we have kept in touch ever since. I later did an update on the GAC manual and became the sole distributor for the GAC Plus on the C64 and, did occasional playtesting for Incentive with Crypt, Castle Master and the like. Ian asked me if I would playtest Kit 1 and also write the manual for it and, later on we discussed the possibility of the User Group. So here we are!

I have a unique ability to make the most awful blunders, am quite a scatterbrain really. I tend to switch on blenders in the kitchen without the lid on them - that kind of thing and tend to format important disks by mistake! I'm fond of pets, we have a dog (as anyone who has used the telephone helpline will no doubt know already!), budgie, hamster and three tanks of tropical fish. All rather boring really - betcha wish you hadn't asked now, Pete!.....Mandy

PIRATES CUT THEIR OWN THROATS!

You may think that that is rather a strange statement. It isn't really. We all know that software piracy is rife - I suppose it will always be with us until programmers manage to come up with a fool-proof method of software protection that will beat the hackers. Legion, the notorious software pirate has boasted in the past - in print - that he makes a point of hacking into every program he comes across - despite the fact that many of them only cost a couple of ££'s to buy. Pirates are proud of the fact that they can beat the programmers protection - it is almost like a point of honour that they must crack into each and every game they can get their hands on. What the pirates don't think about is the fact that they are actually causing the death of their beloved computer!

I know I am not going overboard with that statement. It has been said before in reference to the fact that a lot of companies refused to support the Atari ST in the past because piracy was rife and they lost so much money because of this. It takes an awful lot of money to produce a piece of software commercially. Not only in basic costs, time and energy but in the fantastic sums that have to be laid out for advertising, promotion and the like that go towards the launch of a game. When, because of piracy, so few copies of a game are sold that the costs of producing the thing in the first place are not recovered and a loss is made then a company will think very carefully before venturing down that same road again.

This has happened recently and very close to home! It has happened with the Archimedes version of 3D Kit! I only discovered this when some Archimedes members wrote in to say that, following an upgrade on their machines the 3D Kit didn't work and asked if their programs could be exchanged for another version that would work. Sadly the answer that came back was this: As only a couple of hundred copies of the Archimedes version of Kit1 had been sold, despite the market being flooded with pirated copies of that version, neither Incentive or Domark had any intention of producing any other versions for that particular machine. A huge amount of money had gone into producing that version and that had been lost! So the Archimedes pirates have ruined things for the honest users of that particular machine! It is very sad. If they continue to copy software at that rate I wonder how long it will be before that fabulous computer becomes obsolete because eventually all software companies will drop it like a piece of red hot coal? It really makes you think doesn't it? How many types of computers in the past have vanished through the same thing? Is there anything that WE can do about the situation to prevent the same thing happening to OUR favourite computer?

Do you, like myself, groan everytime you have to turn a wheel which is black on black and try to read the dark grey numbers in order to enter a code to load a game, or have to skim through pages and pages of codes to match the question on screen or the other hundred and one different procedures we have to go through to load software? As long as pirates are allowed to continue the way they are doing then we will have to put up with it! It's nice to be able to load 3D Kit without all that rigmarole isn't it, but how long will we be able to do it without similar protection? If anyone out there is contemplating making a copy of their software to pass on to a friend, then all I ask is that they stop and think for a moment or two - are they perhaps sounding the death knell for their beloved computer? Will that one little copy make a difference? The answer is YES!.....Mandy

THE USER GROUP GAME (PT 3)

KIT 2 UPDATE

IBM PC COMPATIBILITY ISSUES USING V2.03 OR ABOVE

Incentive tell me that: "due to the wide variety of PC compatibles and the massive range of software and hardware available, some of which include Device Drivers and Terminate and Stay Resident (TSR) programs, there are an infinite variety of possible combinations and set-ups available. This means there may be compatibility problems between various hardware and software set-ups and a product as complex as 3D Construction Kit 2/Virtual Reality Studio 2.

CLEAN MACHINES: We have tested the product on a quantity of PC compatibles. During each test we make sure that no unnecessary device drivers or TSR's are loaded, this can be done by simply renaming the files AUTOEXEC.BAT and CONFIG.SYS on the root directory of your hard disc to AUTOEXEC.OLD and CONFIG.OLD respectively and then rebooting the system, this results in a completely "clean" machine. When the tests have been carried out in this manner we have encountered no compatibility problems. Please not however that if this course is taken to ensure a clean machine it will be necessary to install the mouse driver by hand, to do this follow the instructions in your mouse documentation (usually simply typing "mouse" will suffice). Also when returning to normal operation of the machine you will need to rename the files to their original names and reset.

SOUNDBLASTER PRO COMPATIBILITY. There have been reports of problems when using a Soundblaster Pro Card. We have noticed a problem with this card and certain mouse drivers and have included a small fix in the program at release V2.03 that should help to solve this problem. However the program requires that there are no unnecessary drivers or TSR's loaded and that the mouse driver used is fully Microsoft compatible, the mouse driver we used during the tests is the official Microsoft driver version 7.04.

MOUSE DRIVER PROBLEMS. Some mouse drivers seem not to work with either the 3DEDIT program or the 3DSOUND program. We have tested these programs with various Microsoft compatible drivers and found no problem. As such the only solution is to try to obtain a different mouse driver and test the programs with that and ensure that the machine is "clean".

Useful advice would be perhaps to make a startup disk which has no unnecessary drivers on it and to boot from this disk when using 3D Kit2 only - this should save you the bother of re-installing all your other gear later. I'm no expert on the PC so if I am wrong in this then I'm sure someone will kindly let me know..... Mandy.

BOUQUET BOX

Apart from the usual HALL OF FAME to thank members for their contributions some people deserve a special word of thanks for the special help they have given. These people are:

MIEKE VAN DER POLL for the outstanding amount of contributions she has kindly submitted. Not only has she been regularly offering help to us all but almost as soon as she received Kit 2 she sent in loads of help, advice and routines for the newsletters on this version also! **TONY HARTLEY, MARK ROSE** and **MR J.C. LATTY** for kindly agreeing to help out with the playtesting of Version 2.04 at a moments notice. Sorry to put you all on the spot like that!

The only way to adequately express my gratitude is a public THANK-YOU to you all - you have all been gems!

We haven't done any work on our game since the first parts in issues 7 and 8 and a plea for help from Margaret Christmas spurred me into action. Margeret wanted to know how to program another problem into our game. She wanted to make the Solar (where we hid our key) into a completely dark location unless we had first obtained a source of light. I also received a letter from Mr E.R.Horn telling me how to do exactly the same thing on the 8 bit computer so, here is how we do it.

The first thing we should do is to create an identical area to the Solar. On 16/32 bit it is very simple - 8 bitters will have to do it all by hand I'm afraid. Firstly we should go to Area 5, the Solar, and CREATE GROUP. Now we should select ALL the objects contained in that area APART FROM THE GROUND CUBE into that group and save that group as an object. Next we create another area (Area 7) which, via the EDIT AREA command we change the name to read DARK SOLAR. Now load in your saved object and you have an identical area.

Before we make it dark - and thereby confuse ourselves - we have to create a condition for the doorway to read exactly the same as that for the original Solar:

16/32 BIT	8 BIT
IF COLLIDED?	IFHIT (r) rectangle number
THEN GOTO (3,4)	THEN
ENDIF	GOTO 3 4
	ENDIF

Now stand with your back towards the rectangle as if you had just entered the location and CREATE ENTRANCE. This will be Entrance 002.

Colour the rectangle (doorway) in dark grey and everything else within the location BLACK. This is so that we allow the player to at least find the way out if they get stuck inside the Dark Solar - we have to be fair.

Next we have to create our source of light. I went into the Great Hall (Area 2) and created a wall sconce with a flaming torch in it. The objects that made up the torch were 11, 12 and 13. Then on the handle (number 11) I created the following condition so that the torch would become invisible if activated (taken).

16/32 BIT	8 BIT
IF ACTIVATED?	IFACTIV 11
THEN INVIS (11)	THEN
INVIS (12)	INVIS 11
INVIS (13)	INVIS 12
ENDIF	INVIS 13
	ENDIF

Now go to the Alchemists Chamber (Area 4), activate the book in the bookcase to make the doorway visible and edit the existing condition on the doorway to read:

IF COLLIDED?	IFHIT (r)
THEN IF INVIS? (11,2)	THEN
THEN GOTO (2,5)	IFVIS 11 2
ELSE GOTO (2,7)	THEN
ENDIF	GOTO 2 7
ENDIF	END
	ELSE
	GOTO 2 5
	ENDIF
	ENDIF

8 Bit users might like to try the alternative method sent in by Mr Horn who says that he created two identical rooms (areas) numbered 1 and 2 and coloured one black and white and the other one blue and yellow. Each room has a switch (a pyramid mounted sideways on the wall).

Mr Horn says that the object numbers of the switch pyramids must not be the same in either area, or the change from Area 1 to Area 2 will just "toggle" back to the start area and spoil the required effect. Also the entrance numbers sed must not exist as entrance numbers in the entrance tables so in his construction of the areas, number2 was a cube not an entrance. This enables the players position to remain unaltered as the areas change.

The LOCAL CONDITION USED was:

```

AREA 1
      IFACT      009 (switch pyramid)
      THEN
      GOTO      002      002
      ENDIF
      END

AREA 2
      IFACT      007 (switch pyramid)
      THEN
      GOTO      002      001
      ENDIF
      END

```

If you would like to see the Clubgame expanded further - and this would be extremely useful for newer members - then please write in with your ideas for problems that could be included within the game. Just an idea will do as, if you don't quite know how to program what you want to do, then I can do this as with this issue on the light/dark problem. It will help me with ideas of what you want to see incorporated within the game. If you have the routine already worked out then send that in too as that will be extremely helpful.

HALL OF FAME

Sincere thanks to all the following members who kindly sent in contributions for the Newsletter during the past two months:

LIAM JOHNSTON, PETER D. WARD, DAVID SAMBROOK, IAN YOUNG, GERRY WISHART, CHRIS LOWIS, J.P. MESSENBIRD, STEPHEN MOORE, JOHN HAYWARD, MIEKE VAN DER POLL, E.R. HORN, TONY HARTLEY, JOHN ELLIOTT, FRANK CARR, ORN JONASAR, DOMINIQUE WATSON and MARGARET CHRISTMAS.

Special thanks to Dominique Watson for the cover for this issue. A few people have asked me who did the cover for the last issue as the name wasn't clear. It was Al Straker.

ALL members are cordially invited to send in contributions for the next issue, anything from a small hint to a full blown article will be gratefully received. The more ideas we have the more help for everyone and the bigger the Newsletter! Next issue is April/May 1993.

PALETTE CHANGES

By Peter D Ward - ATARI ST KIT 1 and 2

(I have received a lot of moans and groans from Amiga and Atari ST owners about the, rather unfortunate, colour palette in Kit 2. Peter has come to the rescue with some timely tips on this.....Mandy)

Atari ST users have probably noticed the strange choice of default palette on the Kit II. This can give a strange appearance to the clip-art supplied. For example, when loading my own contribution, I was confronted with a rather distasteful looking green chicken in an oven! (Well, I've heard of "Green eggs and ham", but green chicken?!) Well the problem is easily solved, with a little work. Change area colours to those of the default palette of the original Kit 1. Not only will you then be able to have normal-looking clip-art, but you will have the old familiar decent spread of colours instead of the supplied palette of predominantly red and green!

Once this is done, if, like me, you find the palette of the original Kit suitable for most normal purposes without alteration, I would suggest you SAVE the empty area with altered colours to disk, and load this for each new area. For convenience, I saved mine to the EDIT FILE of my disk 1 (back-up copy, naturally!!).

For the convenience of those who have (a) never had a copy of Kit 1 and (b) those who returned it to get Kit 2, and (c) those who can't be bothered to dig out the original Kit disk, here are the original Kit 1 palette values from left to right. See page 15 of the Kit 2 manual to access and edit the colour palette.

For the convenience of those who have (a) never had a copy of Kit 1 and (b) those who returned it to get Kit 2, and (c) those who can't be bothered to dig out the original Kit disk, here are the original Kit 1 palette values from left to right. See page 15 of the Kit 2 manual to access and edit the colour palette.

COLOUR NO.	RED VALUE	BLUE VALUE	GREEN VALUE	COMMENT
1	00	00	00	Invisible
2	15	15	15	White
3	10	10	10	
4	06	06	06	
5	00	00	00	True Black
6	15	00	00	Bright Red
7	15	09	00	
8	15	15	00	
9	15	08	10	
10	09	05	04	
11	12	08	07	
12	00	08	06	
13	00	15	00	Bright Green
14	07	08	15	
15	00	00	15	Blue
16	09	00	06	

(Please note that the Amiga colours are exactly the same as those listed above. I performed the same procedure for the Amiga and it works beautifully on that machine too. Not only that but it only took me exactly eight minutes to do it. Remember that when you have your new colours done you will see that the sky and ground are now both a yucky shade of brown. Don't panic, just select colour as you would to colour an object and selecting a nice pale blue and deep green just click on the sky and ground to change them. I've now got my own area to load in whenever I want and it works beautifully. Thanks Pete for the good advice. I don't need to moan at the colours now!.....Mandy)

PUBLIC DOMAIN LIBRARY

LATEST ADDITIONS TO THE LIST!

ATLANTIS by Mieke Van Der Poll for AMIGA 1meg.

Once again Mieke has provided an absorbing adventure. This time you must explore the undersea world of Atlantis. You start on an island where you must find and gather up 9 pieces of equipment before you head for your boat and the open ocean where you can dive into one of the lost cities of Atlantis. The game is very well programmed with nice music and loading screens. The sound effects throughout the game are extremely good. I especially liked the bubbly underwater sound effects. A most enjoyable game.

TUNES AND SCREENS by Dominique Watson for AMIGA.

At last here is something that all Amiga users shouldn't be without! If you are not in the least musical or non-artistic then this most useful disk contains, not only three beautiful loading screens for your games but also no less than 13 excellent tunes ready for you to use! I cannot think of anything more useful. The screens are beautifully drawn with outer-space themes and the tunes can be played for your selection on the Octamed player provided with the disk!

UTILITIES DISK by Stephen Moore for AMIGA.

Stephen has thoughtfully provided a complete suite of programmes to enable users to create loading sequences for their games. Step by step instructions will be provided with the disk on how to use them. Also on the disk is a useful utility for reading ST and PC datafiles. You may find some difficulty in reading one of these but the whole disk is well worth getting for your collection.

DOCTOR WOW GAMES 1 AND 2 by David Lacey for COMMODORE 64.

At last we have a couple more games for C64 users. In DR WOW I we find the doctor sucked out of his Tardbof together with all his useful objects onto the surface of the planet Scloboros. You should have a great time gathering up all his scattered pieces of equipment and find out why the planet is sucking all your (and the Tardbof's) energy within 1 hour! Great fun! In DR WOW II (Dr Wow and the Dudleks) you discover that the dastardly Dudleks are mining Platercinonium - a powerful rocket fuel! You have to stop them by blowing up the four, interconnecting, mine-shafts. Two great games on one disk which is excellent value.

HYSULA by Peter Ward for ATARI ST.

This is the long awaited sequel to SPEILRAUM and KAKRIVS. What can I say? Yet another fantastic game from Peter which should keep you busy for hours!

FAST-TOWN by Tony Hartley for ATARI ST.

This disk kept me totally absorbed for hours! No, it isn't a game - it's a datafile packed full of objects that will allow you to design and build your own town! The objects include all manner of buildings, roads (including roundabouts, T junctions etc), road-signs, vehicles, phone-booths, benches, trees, lights - the list is endless. I haven't had so much fun for years. Not only is this a most useful suite of objects (all suited to scale 1) but it is a most entertaining way of viewing the excellent objects that Tony has created! - Don't be without this little gem! Also on the disk are some borders which you will find useful too. A completed town is also provided as a datafile and there is a document file with full information. Within the ready-made town there is also a devious maze for you to find your way out of if you enter any of the buildings - serves me right for being nosey!

COMPLETE LIST OF P.D. LIBRARY

Key to what's on the disk/s: G=Complete Game. D=Datafile. B=Border, R=Stand Alone (Runnable) Program. 3DU= Kit utilities. U=Other Utilities. o=Objects.

ALL PD DISKS HAVE BEEN REVIEWED IN FULL IN PRECEDING NEWSLETTERS.

MOUNTAIN ADVENTURE (G/R) by Mieke Van Der Poll - AMIGA.
MOUNTAIN ADVENTURE (D/3DU/B) by Mieke Van Der Poll - AMIGA.
SECRET WEAPON (G/R) by Robin Ball - ATARI ST.
MESSAGE DEMO ROUTINES (D/B/O/3DU) by J. Hayes - AMIGA.
LANDSCAPE DEMONSTRATION DISK (D/B/3DU) by J. Hayes - AMIGA.
FLIGHT SIMULATOR DEMO (D/B/3DU) by Thomas Stufe - AMIGA.
BUILDINGS (D/3DU) by Allan Hern - AMIGA.
SPEILRAUM (G/D/B/R/O) by Peter Ward - ATARI ST.
KAKRIVS (D/B/O/G/R) by Peter Ward - ATARI ST.
HYSULA (R/B/O/G) by Peter Ward - ATARI ST.
ATLANTIS (R/G) by Mieke Van Der Poll - AMIGA 1MEG.
ATLANTIS (G/D/B) by Mieke Van Der Poll - AMIGA 1MEG.
TUNES AND SCREENS (3DU/U) by Dominique Watson - AMIGA.
UTILITIES DISK (3DU/U) by Stephen Moore - AMIGA.
DR WOW I & II (G/R) by David Lacey - COMMODORE 64.
ESCAPE (G/D/U) by Stephen Flanagan - COMMODORE 64.
FAST-TOWN (D/3DU/O/B) by Tony Hartley - ATARI ST.
LIGHTING EFFECTS (D/U) by Robin Ball - ATARI ST.
THE MAZE (R/G) by David Sambrook - ATARI ST.
WEST ONE (G/R) by Frank Carr - ATARI ST.
SOUND SAMPLES (3DU) by Mieke Van Der Poll - AMIGA.
INVENTORY ROUTINE (3DU) by J. Hayes - AMIGA.
BORDERS DISK (3DU) by Robin Ball - ATARI ST.
BORDERS DISK (3DU) by A.J.Bevan - AMIGA.
DARKNESS CALLS (G/R) by James Yusuf - AMIGA.
DARKNESS CALLS (O) by James Yusuf - AMIGA.
PLANET OF THE DALEKS (G/D/B) by Steve Hilder - AMIGA.
E.F.T.P.O.T.C.M. (G/R/U) by Andrew Herbert - AMIGA.
INFILTRATION (G/R) by Robin Ball - ATARI ST.

All the above disks are available from the User Group address - Mandy Rodrigues, 67 Lloyd Street, Llandudno, Gwynedd, LL30 2YP - at a cost of £1.50 each (U.K.). Overseas £2.50 each to cover extra postage costs. All members who send in PD contributions can select freely from the above list as a small thank-you for their contribution and help. Back issues can be sent if preferred or a free issue added to your subscription instead.

PC PUBLIC DOMAIN LIBRARY

PC owners needn't feel left out of things as there is quite an extensive PD library being built up for them by Mark Rose who is kindly offering to run this side of things to relieve some of the workload. For a complete up to date list of what he has on offer please send a stamped, self addressed envelope to: Mark Rose, 3D PC PD, 39 Balfour Court, Station Road, Harpenden, Herts, AL5 4XT.

PLEASE NOTE that the public domain disks containing datafiles are compatible with 3D CONSTRUCTION KIT I and owners of Kit2 will have to modify the names of the datafiles to end with 3WD to be compatible. I hope that by the time of the next newsletter both Mark and myself will have had chance to check out the datafiles and, wherever possible, make them compatible for Kit2 and items will be marked as such.

WHY NOT SENT IN YOUR CONTRIBUTION TO THE PD LIBRARY?

BEGINNER'S SECTION

STEP-BY-STEP GUIDE

MAKING A STRUCTURED PLANNING FOR A GAME ON 3D KIT 2

By *Mieke Van Der Poel* - AMIGA AND PC

As already mentioned in previous Newsletters, it is useful to make and draw your game on a piece of paper, adding as much possibilities and variables as you think you may need to it.

In 3D Kit 2 it is possible to save a whole area with the click of a mouse-button. So if you have divided your game in areas on paper, the first thing you can do is draw the different areas containing all the relevant objects and save each area with an appropriate name so you can easily find which area comes after the other. Having done all this, combine the areas in a datafile. When you save an area, in fact two areas will be saved: Area one, which is always empty and the area you created. When you want to make a datafile, load in your Start-area (which will always be area 2), then, when you load your second area it automatically becomes area 3 - the next loaded area will be area 4 and so on. This means that you have to put area 2 as start-area in the defaults. Having area 1 empty, you could always use that one as the END area.

Make a border, or use one of the provided ones. Add your border in the way described in the manual and add it in the defaults window. Set the view-window and create the necessary text and numerical instruments and other ones if required - i.e. clock, animation etc.). Use the default sound sample file or create your own sounds and load the sound-file. (NB The first time you load the default sound-file you may get the message that the file is not of the required format, if so, quit 3D Kit and load 3D Sound. Load in the default sound-file and save it again. Then you will not have any trouble when loading it in 3D Kit 2).

Now it is time for the most difficult part of game-making: Making GENERAL and LOCAL CONDITIONS, making variables and let them work properly. In my experience the best way to test your program is in the TEST window with the border present, so you can see if your text pops up correctly and if your variables work. Another thing, I cannot emphasize it enough, save your game over and over again and even with different names, so you have spare ones in case something goes wrong. Believe me, with me a lot goes wrong and if I do not save enough I sometimes have to start all over again - and that is very frustrating!

After having gone through all those stages and everything is working fine it is now time to use the MAKE program. Consult your manual for this. If you are happy with your creation then why not send it in to the PD Library, so that many other members can enjoy it and learn from it.

TIP FOR BEGINNERS WITH 3D KIT 2

HOW TO MAKE BEAUTIFUL RIVERS WITH RUNNING WATER AND WATERFALLS

By *Mieke Van Der Poel* - AMIGA AND PC

Creating this realistic effect is extremely simple really. Create a rectangle, move it to the ground and colour it blue. Stretch it into the size you want. Create another rectangle, colour it a lighter shade of blue and place it on top of the first rectangle (002). Shrink it in width and stretch it in length, copy it to the right,

move it a bit to the right, copy that one to the right, move it a bit to the right and perhaps copy another one (so that they overlap). Create a GROUP (mine was group 007) and add rectangles 3, 4, 5 and 6 to the group. Click on the object menu, choose the ATTRIBUTES, click on rectangle (3) and in the edit window click on the FADENUMBER and type in the letter 1. Click on the defaults in the same window - another window pops up - set the fadenummer to 1 also and click on OK. Again click on OK and look at rectangle (3). Do the same with rectangles 4, 5 and 6, then go to the CONDITIONS menu, click on LOCAL conditions, click on CREATE, click again on local conditions, click on EDIT. In the window click on LOCAL CONDITION 1 and type the following in the text window:

```
FADEBOUNCE (7)  
SOUND (1) - optional
```

Click on OK and look at your river, the water seems to be running. Try making an appropriate sound with the sound editor and that will add to the atmosphere. In the same way you can create a waterfall running from a mountain. See the screen dumps below:

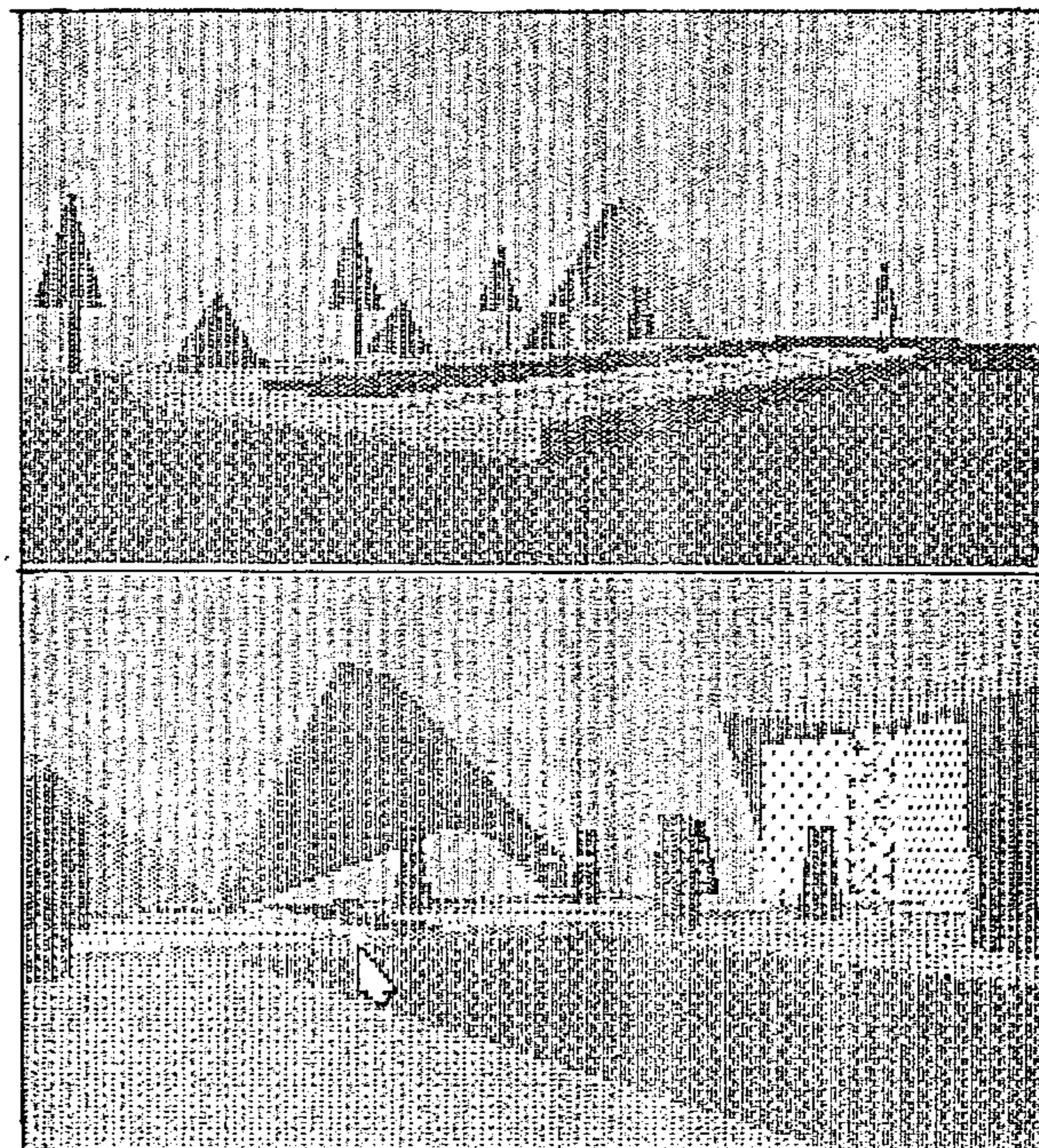

16/32 BIT ROUTINES

LOADING OBJECTS FROM KIT1 TO KIT2

By Mieke Van Der Poel - PC AND AMIGA KIT 1 AND 2

In the manual it states that you can import objects from 3D Kit 1 to 3D Kit 2 if you save them in 3D Kit 1 as a datafile. This can only be done if you, after saving it out as a datafile, use the DOS rename command. So if you saved a hammer in 3D Kit 1 as Hammer.Kit type: rename hammer.Kit hammer 3wd. Then you can leave the file in the object or data directory of Kit 1. Go to the 3D Kit 2 directory, load the editor and load in the Hammer 3wd. Now you can save it out again by deleting the extension 3wd in the file window. 3D Kit 2 will automatically add .3od extension to it.

I have heard from other computer users of Kit 1 that changing the extension to 3wd will enable you to load datafiles and objects to Kit 2 in the same way.....Mandy

PLAYING WITH TIME

By David Sambrook - ATARI ST KIT 1

This is a routine to provide a real time clock inside a location which will constantly update its time as you play. So for example, if you enter the location to find the clock showing five past six and then you re-enter five minutes later the clock will be showing ten past six. For simplicity I will show the clock face as a simple Hexagon with lines for hands. Obviously you can add more detail later.

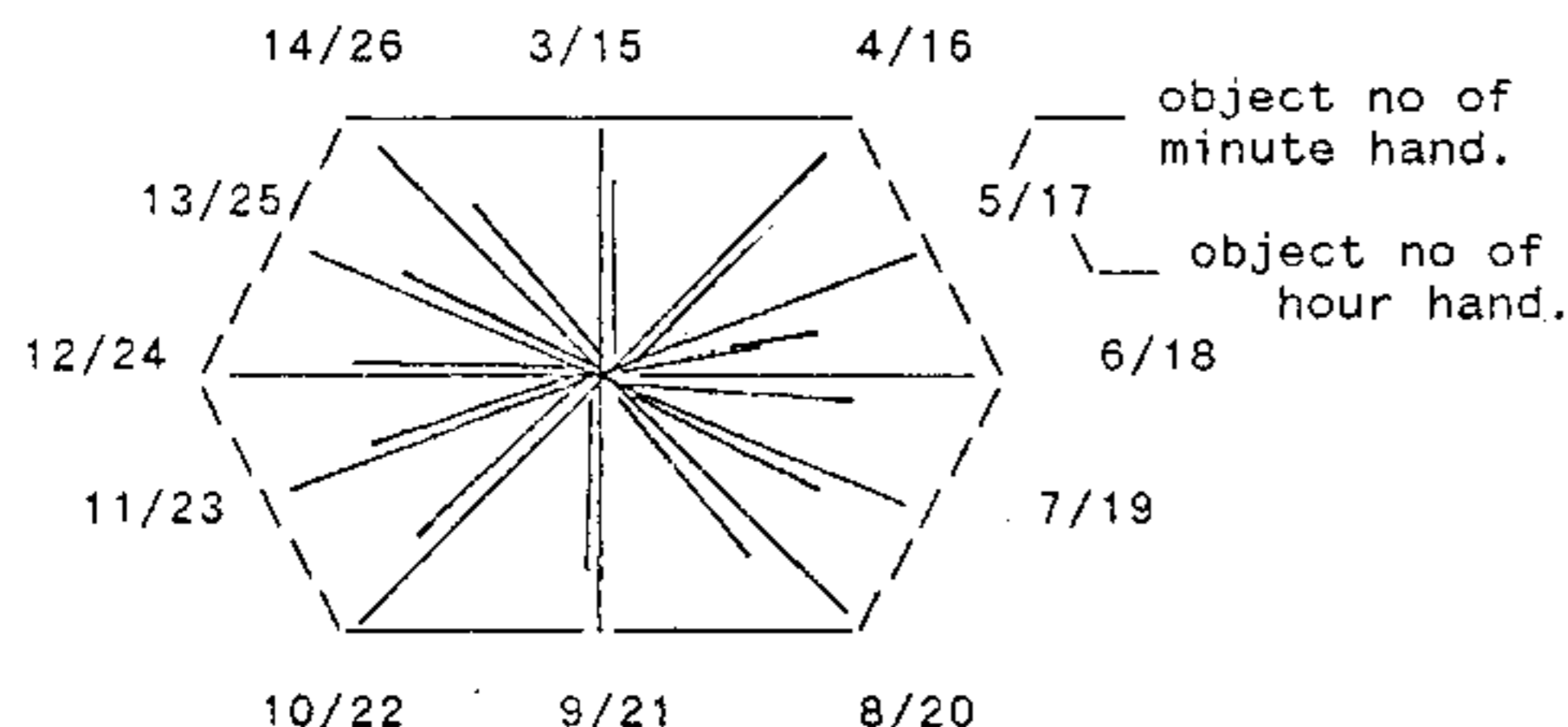

I have used the following variables: V40 = seconds. V41 = minutes. V42 = hours. V43 = five minute counter. V44 = which minute hand is visible. V45 = which hour hand is visible. In your initial General Condition you need to set the start time, e.g. If you want to start at 3 o'clock you would use:

INITIAL CONDITION 1

```
SETVAR (0,V40)
SETVAR (0,V41)
SETVAR (3,V42)
```

You also need to set all the hands attributes (under the OBJECTS menu), to initially INVISIBLE all lines other than lines 3 and 18 (to show 3 o'clock). You then need to add these General Conditions:

GENERAL CONDITION 2

```
IF TIMER?
THEN ADDVAR (1,V40)
ENDIF
```

GENERAL CONDITION 3

```
IF VAR>? (V40,59)
THEN ADDVAR (1,V41)
ADDVAR (1,V43)
SETVAR (0,V40)
ENDIF
```

GENERAL CONDITION 4

```
IF VAR>? (V41,59)
AND VAR>? (V45,26)
THEN ADDVAR (1,V42)
SETVAR (0,V41)
INVIS (V45,1)
ADDVAR (1,V45)
VIS (V45,1)
ELSE IF VAR>? (V41,59)
AND VAR=? (26,V45)
THEN SETVAR (0,V42)
SETVAR (0,V41)
SETVAR (0,V40)
INVIS (V45,1)
SETVAR (15,V45)
VIS (V45,1)
ENDIF
```

GENERAL CONDITION 5

```
IF VAR=? (12,V42)
THEN SETVAR (0,V41)
SETVAR (0,V42)
SETVAR (0,V40)
ENDIF
```

GENERAL CONDITION 6

```
IF VAR=? (5,V43)
AND VAR<? (V44,14)
THEN INVIS (V44,1)
ADDVAR (1,V44)
VIS (V44,1)
SETVAR (0,V43)
ELSE IF VAR=? (5,V43)
AND VAR=? (V44,14)
THEN INVIS (V44,1)
VIS (3,1)
SETVAR (3,V44)
SETVAR (0,V43)
ENDIF
```

You will notice that all the VIS and INVIS commands contain the number 1, this should be set to the location your clock is in and allows the clock to continue updating even when you are not in that location. This also has the advantage that variables V40 and V42 always store the game time so for example you could place these onto the instrument panel to simulate a small digital watch carried by the player. On the down side, this clock does keep terrible time. It tends to lose seven seconds every five minutes. But still, this is only virtual reality!

MAKE THOSE LIFT MOVEMENTS LOOK REAL

Bt *Frank Carr* - ATARI ST KIT 1

Here is a simple routine to make a lift movement look real. Construct a lift with two sliding doors and small cube for the lift button. Reduce the button on attributes to 5 by 5 by 5. Create two animators for the doors. Animator for the left door:

```
START      left door  INCLUDE (x)  - x being the number of the
                                LOOP (16)
                                MOVE (5,0,0)
                                AGAIN
                                STOPANIM (1)
                                LOOP (16)
                                MOVE (-5,0,0)
                                AGAIN
                                STOPANIM (1)
                                RESTART
```

The above code is for animator (1). For animator (2), x being the number of the right door, first move command will be:

```
MOVE (-5,0,0)
```

Alter the stopanims commands to:

```
STOPANIM (2)
```

Make the second Move command to be:

```
MOVE (5,0,0)
```

You now have two animators with two sets of code. Now for the condition for the lift button:

```
IF ACTIVATED?
THEN STARTANIM (1)
STARTANIM (2)
LOOP (10)
AGAIN
ADDVAR (10,V1)
REDRAW
DELAY (20)
SUBVAR (10,V1)
REDRAW
STARTANIM (1)
STARTANIM (2)
ENDIF
```

Study the code, see if you can work out what causes the little movement in the lift. As I said in my previous article, try to study other programmers work, buy my game from Mandy, then I won't have to keep writing these routines!

PROGRAMMING A FLIGHT-SIMULATOR PART THREE

By *Thomas Stufe* - AMIGA KIT 1

Continued from the last issue.

FLYING CHARACTERISTICS

The aircraft has to move without pressing a button. There is only one way to program this, that I know of, the following routine isn't very elegant, but does simulate a more realistic aircraft movement. Due to the lack of trigonometrical functions in 3D Kit I had to "simulate" these functions. The following variables are used:

v = speed of aircraft. hdg = heading (V4). cu = current use of

fuel. x = V0. z = V2.

I split up the heading circle into 12 parts to 30 degrees:

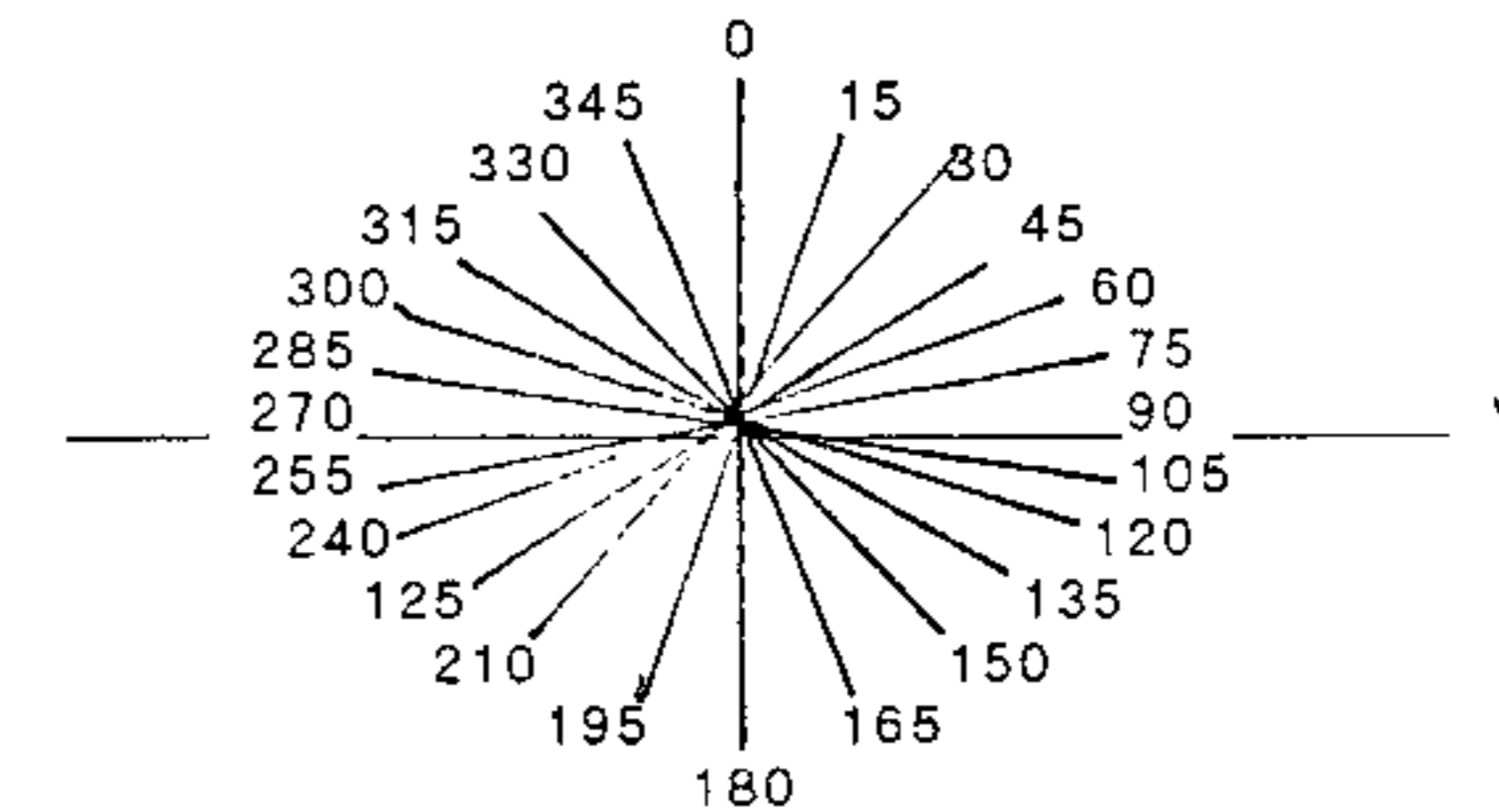

V is used as a vector and is added or subtracted from the current position of the aircraft - from variables V0 and V2. Here is the code:

GENERAL CONDITION

```
IF VAR<? (344,hdg)  - if hdg between 345' and 15'
OR VAR>? (15,hdg)
THEN ADD (v,z)      - then add 2*v to z
ADD (v,z)           - it means that you go north
ENDIF
IF VAR>? (45,hdg)  - if hdg between 15' and 45'
AND VAR<? (14,hdg)
THEN ADD (v,z)      - add 2*v to z and add v to x
ADD (v,z)
ADD (v,x)
ENDIF
IF VAR>? (75,hdg)
AND VAR<? (44,hdg)
THEN ADD (v,z)
ADD (v,x)
ADD (v,x)
ENDIF
....
.... - and so on...
....
IF VAR>? (345,hdg)
AND VAR>? (314,hdg)
THEN ADD (v,z)
ADD (v,z)
SUB (v,x)
ENDIF
REDRAW
```

The result is that the aircraft moves (approximately) to the point fixed on the cross. Now it is possible to delete the forward/backward movements (ndef) in the control menu. The following routine allows you to vary the speed - pressing the "+" and "-" buttons and calculates the current use of fuel:

GENERAL CONDITION

```
IF VAR=? (43,V15)
THEN
```

```

SETVAR (0,V15)
ADDVAR (10,v)
ADDVAR (1,cu)
IF VAR>? (100,v)
THEN SETVAR (100,v)
ENDIF ENDIF

```

```

IF VAR=? (45,V15)
THEN
SETVAR (0,V15)
SUBVAR (10,v)
SUBVAR (1,cu)
IF VAR>? (0,v)
THEN SETVAR (0,v)
ENDIF ENDIF

```

The movement routine is related to the circle on the x/z plane. It is possible to do the same on the y/z plane but there are difficulties. On the points v3 = 270 (zenit) and v3 = 90 (nadir), v4 and v5 have to rotate 180 degrees and v3 has to reflect on the 90-270 degree line. Also it is necessary to delete "move up", "move down", "rotate up" and "rotate down" in the control menu and to create a routine which calculates the angle v3 dependent on the tilt angle v5, requesting the keyboard, and which change the sign of the step of v3 on the zenit/nadir.

But for all those routines only one REDRAW is necessary! The calculations don't take time, but the painting of the surrounding area does.

For some people, the movement in this 3D-grade-split heading seems to be a bit rough. Of course it is possible to split it finer, but it is a lot of work. All these routines can be seen, working on my PD disk, available from Mandy.

STOP PRESS!

AMIGA KIT 2. I've heard from quite a few Amiga owners who say they cannot load the Clip-Art files from disk two. I may be wrong but I think, from speaking to a few of them, that the problem only occurs on single-drive users. The problem is being fixed for version 2.05 but I would be grateful if anyone with double drive who has experienced this problem, could let me know if I am wrong in my assumption.

GENERAL KIT 2. Quite a few people have complained that some of the FCL commands as printed in the manual don't work, such as ANIMBRUSH. In the addendum to the manual it is explained that some commands have been changed so that it should be BRUSHANIM. Others are BRUSHANIMACTIVE?, DISABLEBRUSHANIM, ENABLEBRUSHANIM etc etc. Don't forget to read the addendum to the manual for a list of all changes.

The programmers are working hard on version 2.05 at this moment and it should be ready within a few weeks. I'll arrange to swap disks once I get a stock in.

In the beginners routine by Mieke Van Der Poll, please make sure you load in your border first to avoid problems with colours later.

8 BIT ROUTINES

INVENTORY/INFORMATION SCREEN

By *David Lacey* - COMMODORE 64

Newsletters issues 2, 3 and 6 all had very good ideas on this topic but, either they did not suit my game, or were a little bit complex. So I thought about making a black background for my information screen, and decided to make it using an empty message. The method I will outline now gives an information screen when the letter "I" is pressed, but note that "I" has to be held down for a short time depending on how complex the current 3D view is. To exit the screen "I" must be held down again. Variable messages (such as what you are carrying) will flash when they appear, but this actually creates a good effect. In my game the conditions and procedures used are: General conditions 11 and 4 and procedure 20.

The first General Condition is as follows:

```

CMPV    73    121  (73 = ASCII "I")
IFEQ
THEN
ADDV    1    105  (105 is just a variable
ENDIF    initialized as 0 in Gen.Con.1)
CMPV    1    105
IFEQ
THEN
CALL    1
ELSE
IFGT
THEN
SETV    0    105
SETV    1    17  (Var 17 is text clear flag)
ENDIF
END

```

Second General Condition:

```

CMPV    1    17
IFEQ
THEN
SETV    0    17
COLOUR  0    0
ENDIF
END

```

Procedure 1:

```

TEXTCOL 3
PRINT   2    4    4  }
PRINT   3    4    6  } - Permanent Messages
PRINT   4    4   15  }
PRINT   1    4    5  }
PRINT   1    4    7  }
PRINT   1    4    8  } Gaps between messages (note
etc                                           exclude lines which messages are
                                           on: In this case lines 4, 6
                                           and 15)
PRINT   1    4   14  }
PRINT   1    4   16  }
CMPV    1    4    } - Variable for key (1=yes 0=no)

```



```

IFEQ
THEN
PRINT 5 4 7 ] - Flashing messages of objects
ENDIF ] you have.
CMPV 1 1 ] ----- Variable for having jetpack
IFEQ ] jetpack (1=yes 0=no)
THEN
PRINT 6 4 8
ENDIF
and so on for as many objects as you wish.
END

```

Now create the following messages:

```

MESSAGE 1: " (BLANK) "
MESSAGE 2: " INVENTORY SCREEN "
MESSAGE 3: " YOU ARE CARRYING THE FOLLOWING "
MESSAGE 4: " HOLD KEY "I" TO EXIT "
MESSAGE 5: " THE KEY "
MESSAGE 5: " THE JETPACK "

```

Note that all messages must be the maximum length minus one. That is that there should be one "dash" visible at the end of each message, with spaces used to fill out short messages. The above routines work for a window set at X position 4, Y position 4 and with dimensions 32 x 13. For different sized or positioned screen just alter the number, and position of messages and the length of messages - messages too long will go off the inventory screen.

CREATING A REAL-TIME CLOCK

By *David Lacey* - COMMODORE 64

GENERAL CONDITION:

```

TIMER 250
IFTIMER
THEN
ADDV 1 49 (var 49 set to 0 in General
ENDIF Condition 1)
END

```

NEXT GENERAL CONDITION:

```

CMPV (18) 49
IFGT
THEN
SETV 0 49
SUBV 1 50 (var 50 is initialised to
ENDIF 60 in General Condition 1)
END

```

The number in brackets, 18, I found to be pretty accurate for my game, but for one less complex, a higher number will be needed. This is simple to check by just trying various values, and while playing your game, just time it with a watch.

Note that an INSTRUMENT of type "NUMBER" needs to be set up, running on variable 50.

MAKING SOMETHING MOVE WITH TIME

By *Yannick Gour* - AMSTRAD CPC 6128

A.P. Smith (issue 5) and Stephen Flanagan (issue 6) wrote something about this. It is necessary to create as many objects as there are positions for the simulated animation to be moved to. In this instance let us create a cube which is moving along four spaces. We need to create four cubes (only the first one being visible).

Create a cube and make it invisible by using the ATTRIBUTE icon. Repeat this procedure for each one placing them side by side. Make the first cube VISIBLE. The FCL code example:

```

IFTIMER
THEN
ELSE
END - no animation if timer period not passed.
ENDIF
IFVIS 1- if cube 1 is visible
THEN then
INVIS 1 make it invisible
VIS 2 and make cube 2 visible
REDRAW redraw the screen
END stop
ENDIF
IFVIS 2
etc toggle visibility from cube 2 to cube 4
END then from 4 to 1 again

```

If there are too many objects to animate then a second possibility would be to design as many areas as there are positions and instead of toggling visibilities of the objects as in the previous example you have to change areas. This can be done if we write a FCL routine with four areas (from A to D) as follows:

IN AREA A	IN AREA B	IN AREA C	IN AREA D
IFTIMER	IFTIMER	IFTIMER	IFTIMER
THEN	THEN	THEN	THEN
GOTO 0 "B"	GOTO 0 "C"	GOTO 0 "D"	GOTO 0 "A"
ENDIF	ENDIF	ENDIF	ENDIF

TIPS ON COMPILING

By *John Elliott* - SPECTRUM

If you want to change the border after compiling, it is stored in the file "3". It is a standard SCREEN\$ file.

To display a loading screen, insert the instruction LOAD "SCREEN" SCREEN\$ in the DISK file. Any new instructions in the DISK file must be placed in-between the CLEAR and USER instructions.

The 15 different shades are stored in the file "1" at base + 24187. Thus if you load the file CODE 32768, the first shade is at 56955. Each shade is like a half-height user-defined graphic and can be designed in the same way as a UDG. When the game is running you can change them using a Multiface - they are at 66147. Similarly, they are in the 48K environment editor at 65360, the 48K condition editor

at 65267, and the 128K editor at 65263, banks 0 and 3 - change the shade pattern in both memory banks.

If you want to base objects on those in Driller or Dark Side, it is easy to measure objects in these games. Just line up your movements sights with the edge of the object and use the X, Y, ↑ values to measure the distance across the object. Divide by 64 to get "object" co-ordinates, X, Y, ↑ in these games correspond to X, Z, Y in the 3D Kit. Here is a picture of a Driller-type rig which I reverse-engineered this way:

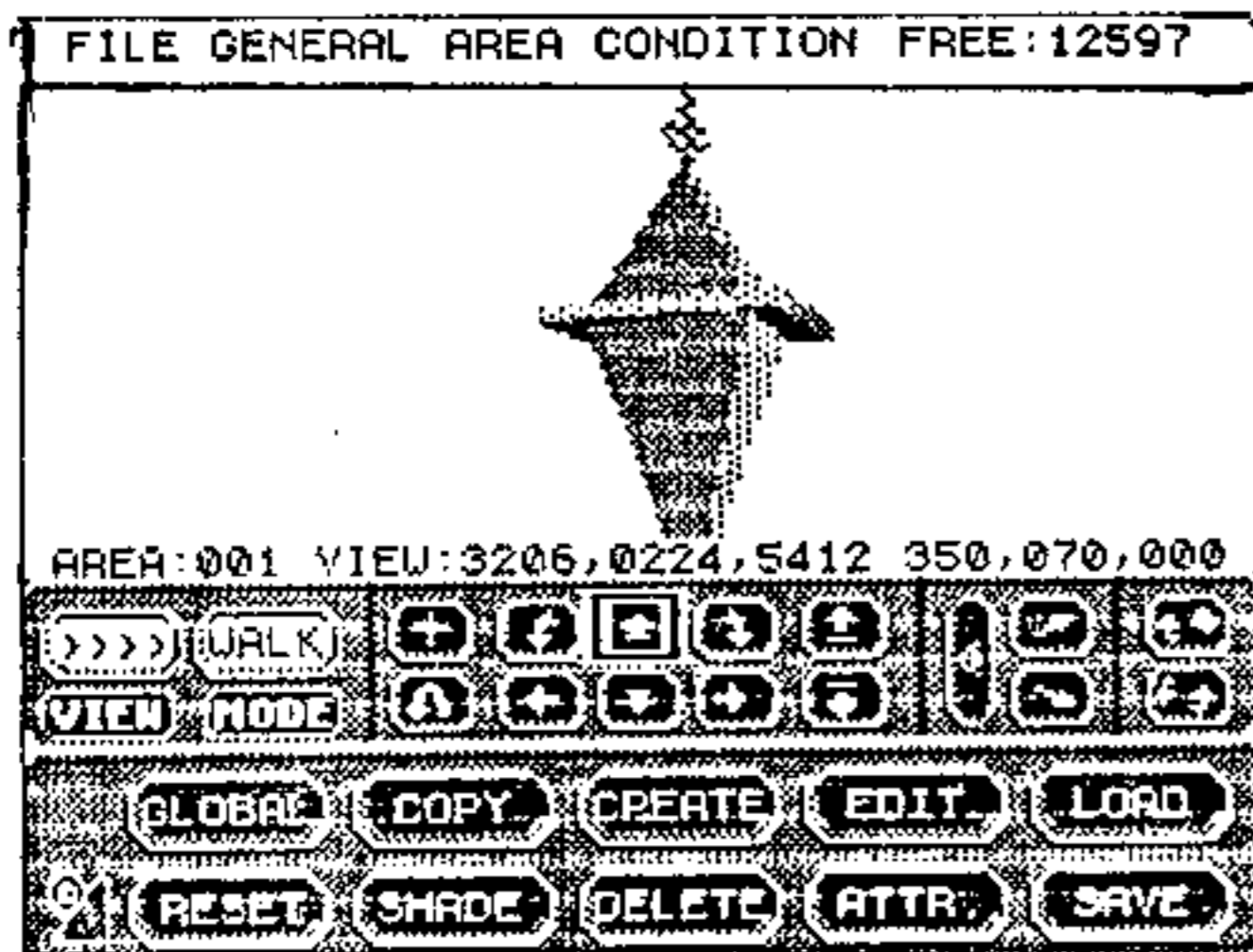

PROXIMITY DETECTOR:

There is a way to get this done which hopefully will save memory. Instead of having all those rectangles on the floor, have four sensors at the same place (on or above the point you wish to measure from). Using ATTRIBUTES, set the first sensor's size to 100,100,1, the second sensor to size 80,000,1, the third to 60,000,1 etc. Then use David Lacey's detector routine (Issue 10), except that IFHIT should be replaced by IFSENSED.

CALLMC information and machine-code programming.

If you are not a machine code programmer, the information below will probably not make any sense. Also, this is specific to Spectrums. You have been warned! CALLMC only works once a game has been compiled. The form is CALLMC 1 h where L and H are the low and high bytes of the address to call. If you write a machine-code routine for CALLMC there are a number of interesting addresses. These addresses are only valid for the compiled versions of games - anyway, CALLMC has no effect in the editors. All addresses are given in Hex.

- AA56 -If set to 1, reset the environment as if ENDGAME had been typed.
- AAE5 -The text colour (as set in TEXTCOL).
- B569 -The IF flag. If 0 the commands to next ENDIF will not be used.
- B612 -FCL variable number 0, each variable occupies 1 byte so variable 1 is at B613 etc. This is probably the best way of passing parameters.
- B693 -The IF combiner byte. If it is 0 there are no previous IFs. If it is 1, there was a previous IF-AND. If it is 2 there was a previous IF-OR.
- B695 -The FCL zero flag. If set to 0 IFEQ will return true.
- B696 -The FCL carry flag. It determines responses to IFGT and IFLT.
- C073-4-16 Bit value for the TIMER, only low 8 bits set by the FCL TIMER command.
- C077 -A sound number put there by SYNCSDND waiting to be used.
- CO8A -The crush byte, set to 1 to indicate death by crushing.
- CO8B -The fall byte, set to 1 to indicate death by falling.

When a routine is entered from CALLMC, the DE register indicates the address of the routine. The IX register indicates parameter addresses; (IX+1) is parameter 1, (IX+2) is parameter 2 and (IX+3) is parameter 3. For CALLMC the first two are the address of the routine, and there is no third (this can be changed in the table of commands in the compiler, there is an entry for CALLMC beginning with "CALLMC ". Immediately after this is a byte containing the value 2; change this to 3 in both the editor and compiler. CALLMC will then take three inputs; the third is only used by your machine code program. The easiest way to do this modification is with a Multiface. If you actually want to alter or replace an FCL command, they are stored in the following format:

- DEFB "NAME " - 8 spaces.
- DEFB Numarg - number of inputs afterwards
- DEFB Number - probably the command number
- DEFB ADDR - address of the routine used by the command

The only problem is where to load machine-code routines. The "1" file occupies all the memory from 40960 up; the game code "2" loads at 24576 and the machine code loader "LOAD" at 24064. There seems to be some spare space at 65384-65535 but code for here has to be loaded after the file "1". The best option seems to be to create a mini-program looking something like this:

```

ORG 24320
LD HL,MC
LD DE,65384
LD BC,MCLen      -machine code length
LDIR
JP 41888         -enter the game
MC               -your machine code routine goes here
                 it is assembled to run at 65384.

```

Save this program as XCODE.BIN or something similar. Then modify the "LOAD" file so that the JP 41888 at the end becomes JP 24320. Save the modified "LOAD" file to replace the original one. Finally make a loader program which loads "XCODE.BIN" at 24320 and then loads the normal "DISK" program.

TAKING A DIP

By Garry Wishart - SPECTRUM +3

I have been trying to get the effect of a player getting into a pool of water. This allows the player to have their head half out of the water (if you know what I mean). The effect can be achieved by creating a large cube for the player to step off and then creating a rectangle the length of the area and the height of the cube. Colour the rectangle in a suitable "water" colour (say cyan). Copy the rectangle twice more and edit them so that they form a complete box around the area. If you are a bit bewildered by my explanation (even I was at first!), then refer to my diagram:

